

WORKING POSITION

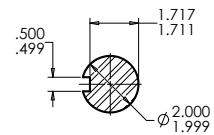
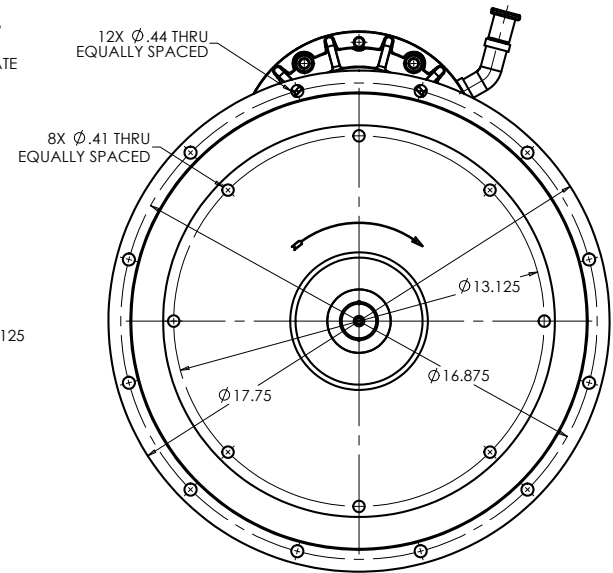

SECTION A-A

GEARBOX DATA:

- INPUT: POWER: 100 HP
- SPEED: 2400 RPM.
- RATIO: 1:1.19 (SPEED INCREASER)
- ROTATION: ANTI-ENGINE.
- LUBRICATION TYPE: BATH.
- SUMP CAPACITY: 1.5 QT APPR.
- SURFACE FINISH: CASE- NATURAL ALUMINUM.
- APPR. WEIGHT: 120 lbs W/O OIL.

		RJ Link International, Inc. Rockford, IL 61109, USA		THIRD ANGLE PROJECTION
<small>This document is the property of RJ Link International, Inc. and is loaned to the recipient for his confidential use only in consideration of the loan of this drawing. recipient promises and agrees that it shall not be used in any way detrimental to the interest of RJ Link International, Inc., that it shall be returned upon request, and it shall not be reproduced, copied, loaned or otherwise disposed of directly or indirectly without the expressed written consent of RJ Link International, Inc.</small>				
DESCRIPTION SPEED INCREASER				
DRAWN: MMM CHECKED: JO ENG APP: JO	DATE: 4/5/2017 DATE: 4/5/2017 DATE: 4/5/2017	D 1:2	PART # D101A119001	SHEET 1 OF 1 00