

WORKING POSITION

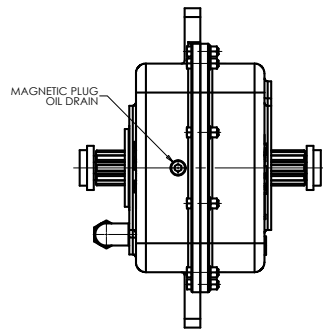

GEARBOX DATA:

- INPUT CAPACITY: 200 HP @ 1400 RPM
- INPUT SPEED: 1800 RPM MAX.
- RATIO: 1.03:1
- ROTATION: **ANTI-ENGINE.**
- LUBRICATION TYPE: **BATH.**
- LUBE CAPACITY: 1.75 GALLONS APPR.
- APPR WEIGHT: 250 lbs W/O OIL.

		RJ Link International, Inc. Rockford, IL 61109, USA		THIRD ANGLE PROJECTION
This document is the property of RJ Link International, Inc. and is loaned to the recipient for their confidential use only. In consideration of the loan of this drawing, recipient promises and agrees that it shall not be used in any way detrimental to the interest of RJ Link International, Inc., that it shall be returned upon request, and it shall not be reproduced, copied, loaned or otherwise disposed of directly or indirectly without the expressed written consent of RJ Link International, Inc.				
DESCRIPTION TRANSFER CASE		DRAWING SIZE D		
DRAWING NO. D181A103002		SCALE 1:2.5		
CHECKED JO	DATE 10/03/2017	PART FILE	SHEET 1 OF 06	
ENG APP JO	DATE 10/03/2017			